

THIS DRAWING IS UNPUBLISHED.

RELEASED FOR PUBLICATION

© COPYRIGHT - By -

ALL RIGHTS RESERVED.

LOC	DIST	REVISIONS			
P	LTR	DESCRIPTION	DATE	DWN	APVD
AF	50	E2	REVISED PER ECR-11-025270	20DEC11	KH GJ

- 1 PRODUCT PROVIDED IN STRIP FORM ON REELS;  
BREAKS MAY BE PRESENT
  - 2 REF CRIMPING INFO:  
4.57 [.180] CRIMP WIDTH AT CRIMP HEIGHT = ( CMA+23,100 ) /285,700  
5.58 [.220] CRIMP WIDTH AT CRIMP HEIGHT = ( CMA+24,500 ) /330,000
  - 3 REF SIMILAR SLICE P/N 1217967-X WITH SERRATIONS
- △ 4 LUBRICATION MAY BE REQUIRED TO FACILITATE CRIMPING. A PRODUCT LUBRICANT APPLICATOR IS AVAILABLE FOR TE CONNECTIVITY TERMINATION EQUIPMENT.

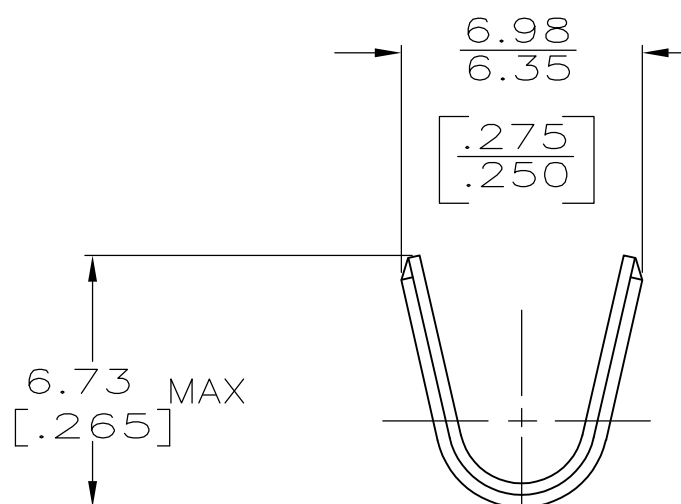
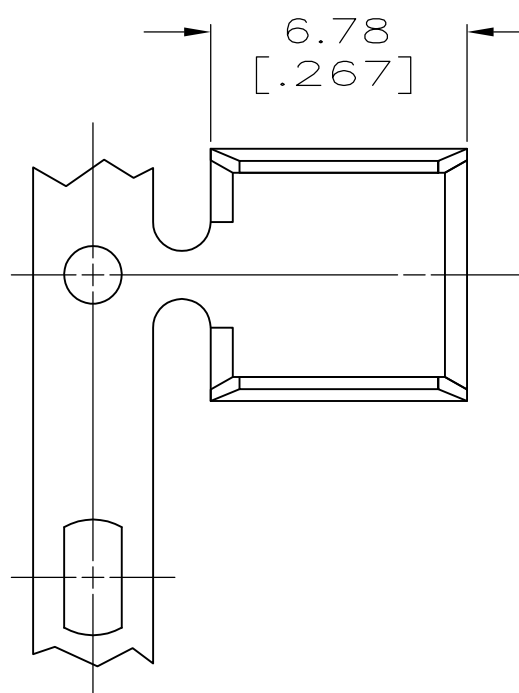

0.635±0.025  
[.025±.001]

TIN	2.5-8.1mm <sup>2</sup>	63625-2
-	5,000-16,000 CMA	63625-1
FINISH	WIRE RANGE △ 4	PART NO

THIS DRAWING IS A CONTROLLED DOCUMENT.		DWN P FORTNEY 10/3/91	 TE Connectivity NAME SPLICE											
DIMENSIONS: INCHES		CHK MS FEHER 10/4/91												
TOLERANCES UNLESS OTHERWISE SPECIFIED:		APVD R WEAVILL 10/4/91												
<table border="0"> <tr><td>0 PLC</td><td>± -</td></tr> <tr><td>1 PLC</td><td>± -</td></tr> <tr><td>2 PLC</td><td>± 0.25 [.010]</td></tr> <tr><td>3 PLC</td><td>± -</td></tr> <tr><td>4 PLC</td><td>± -</td></tr> <tr><td>ANGLES</td><td>± -</td></tr> </table>		0 PLC				± -	1 PLC	± -	2 PLC	± 0.25 [.010]	3 PLC	± -	4 PLC	± -
0 PLC	± -													
1 PLC	± -													
2 PLC	± 0.25 [.010]													
3 PLC	± -													
4 PLC	± -													
ANGLES	± -													
MATERIAL BRASS	FINISH SEE TABLE	APPLICATION SPEC 114-2088	SIZE A3	CAGE CODE 00779	DRAWING NO C-63625	RESTRICTED TO -								
CUSTOMER DRAWING			SCALE 5:1	SHEET 1 OF 1	REV E2									